



samlexpower

**Battery Guards
BG Series**

**Model:
BG-40
BG-60
BG-200**

**Owner's
Manual**

Please read this
manual before
operating your
unit

DESCRIPTION

The universal programmable Battery Guard (BG) prevents the excessive discharge of the battery (which would damage the battery) and protects electronic appliances against over-voltage. The BG has an "Automatic Board System Detection"; the BG automatically detects the battery voltage (12 or 24V). This does not need to be programmed manually. Three models are available in the BG Series: 40A (BG40), 60A (BG60) and 200A (BG200). The internal MOSFET is capable of carrying either 40A (BG40), 60A (BG60), 200A (BG200) continuous load and up to 45A (BG40), 65A (BG60) and 210A (BG200) transient load.



BG40/60



BG200

The new Battery Guard BG40/60/200 (hereafter called BG) is an intelligent, watertight, Battery Guard with accessory connections to accommodate a ON/OFF switch, Alarm buzzer or relay and our CurrentWatch current sensor (not included).

The unit has two bolts as connection for the "Input+" and the "Output+" to guarantee low losses. Other connections, like the minus and the accessories, are made by a 4-pole 6.3mm faston connector. A blue LED shows the status (ON/OFF). In program-mode it shows the program position.

There is a choice out of 10 on/off threshold voltage programs, for both 12V and 24V Battery Systems, which can be easily programmed.

The BG uses very little current. In the OFF mode or when in undervoltage the BG uses just 2mA or less.

FEATURES

Fully programmable

The BG battery guard is microprocessor controlled and can be programmed to engage/disengage at ten different voltage levels for both 12 & 24V Battery Systems.

Overvoltage protection

To prevent damage to your sensitive loads due to overvoltage, the load is disconnected whenever the DC-voltage exceeds 16V or 32V.

Ignition proof

The unit has no relay but MOSFET switches, and therefore no sparks.

Alarm output

The alarm output is activated if the battery drops below the preset disconnect level for more than 12 seconds. Starting the engine, genset or battery charger will therefore not activate the alarm. The alarm output is an open collector output to the negative (minus) rail (max. current 500mA). The alarm can typically be used to activate a buzzer and/or lamp.

Load disconnect

Only 1 minute after the alarm has been activated the load will be disconnected, but if the battery voltage increases to the connect threshold within this minute (after the engine, genset or battery charger has been started for example) the load will not be disconnected.

INSTALLATION

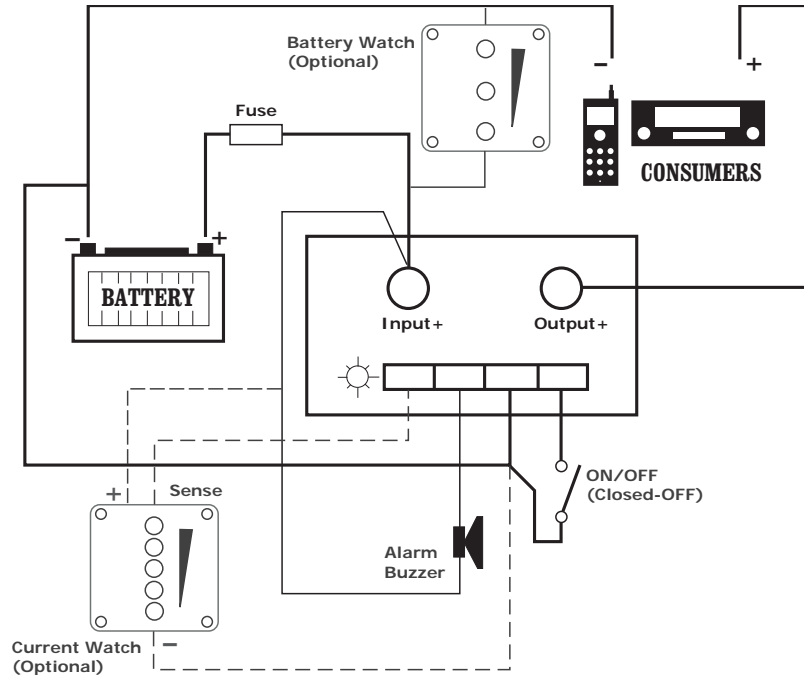

The installation of the BG has to be done by qualified personnel. Working on a battery voltage is not without danger. Use wires of sufficient diameter and connectors of good quality. All connections have to be done via a fuse of the right value. See separate section on wire/diameter for choice of appropriate wire size.

Attention!

- Live wires should never make contact with the case of the BG or the vehicle.
- Wrong connection could damage the internal electronic circuitry.
- Mount the BG on a heatsink (metal), so it can dissipate the generated heat.
- Mount it as close as possible to the battery (max. 50cm). This is the only way to precisely guard the voltage of the battery.
- Do not connect the equipment until the BG is fully programmed.
- Use a 1.5mm² wire for the minus connection which is directly connected to the battery. No other equipment should use this wire.

Remote ON/OFF

It is possible to connect a switch to the BG's "On/Off" terminal. If the "On/Off" terminal is connected to the "Minus" terminal, the BG will shut down the connected equipment after about 1 second. If the connection is removed, the equipment will be started up again after about 1 second. The current through the switch is almost negligible, so a small switch can be used.

Alarm output

A buzzer can be connected to the "Alarm" terminal. The buzzer/alarm will be activated at undervoltage after about 12 seconds. When there is no change in this situation the BG will shut down the equipment approximately 90 seconds later. The buzzer/alarm will also be stopped.

The equipment can be damaged at overvoltage (16V/32V) hence the BG will shut down the equipment immediately and the alarm-output will pulsate. This way you can hear the difference between an undervoltage and an overvoltage alarm.

A second application of this output is with the use of a relay. In this application the BG should be programmed in program-position 12 (default is position 11) . This way the relay will be activated at alarm and when it reaches the upper voltage threshold it will be deactivated again. This way the relay can be used to activate a charger or generator.

CurrentWatch

A CurrentWatch can be connected to the “Prog/Current” terminal. The CurrentWatch will show the current used by your equipment. Contact your supplier, if you are interested in this product.

Wire diameter

Use at least the following wire diameters for the bolt connection:

- BG40 minimum 10mm²
- BG60 minimum 15mm²
- BG200 minimum 50mm²

In difficult environments it is advised to use larger diameters.

The BG will shut down after about 5 seconds when overloaded and will re-start after about 60 seconds on removal the overload condition.

PROGRAMMING

Initially connect the battery to the Battery Guard. To start the program mode a connection should be made between the “Input+” and the “Program Input”. The LED will start flashing. The number of flashes represents the program-position (see table) it is in. As soon as the desired program-position is reached the connection between the “Input+” and the “Prog/Current” terminal Input should be removed as the LED flashes (eg.: to program for position 3, remove the connection between the “Input+” and the “Prog/Current” terminal when the LED flashes for the third time). To confirm the programmed position the LED will repeat the number of flashes. If it is not the right position, the previous steps have to be repeated.

A change in position 11 or 12 has to be programmed separately.

The programmed positions will be remembered, even if the battery connection has been removed. Default program-position are positions 1 and 11. See program table.

After completing the programming the equipment can be connected.

Attention! First remove the battery-connection, connect the equipment to the “Output+” and then reconnect the battery.

| 12 Volt mode | Undervoltage threshold | Re-connect threshold | 24 Volt mode | Undervoltage threshold | Re-connect threshold |
|--------------|------------------------|----------------------|--------------|------------------------|----------------------|
| Position 1 | 10.5V | 12V | Position 1 | 21V | 24V |
| Position 2 | 10 V | 11.5V | Position 2 | 20V | 23V |
| Position 3 | 9.5V | 11.5V | Position 3 | 19V | 23V |
| Position 4 | 11.25V | 13.25 V | Position 4 | 22.5V | 26.5V |
| Position 5 | 11.5V | 13.8V | Position 5 | 23V | 27.6V |
| Position 6 | 10.5V | 12.8V | Position 6 | 21V | 25.6V |
| Position 7 | 11.5V | 12.8V | Position 7 | 23V | 25.6V |
| Position 8 | 11.8V | 12.8V | Position 8 | 23.6V | 25.6V |
| Position 9 | 12V | 13V | Position 9 | 24V | 26V |
| Position 10 | 10 V | 13.2V | Position 10 | 20V | 26.4V |
| Position 11 | Normal alarm | | Position 11 | Normal alarm | |
| Position 12 | Relay function | | Position 12 | Relay function | |

Position 1 & 11: Default positions

Normal alarm: Alarm output activated at alarm; deactivated after 1 minute.

Relay function: Alarm output activated at alarm; deactivated at overvoltage threshold.

SPECIFICATIONS

| Mode | BG40 | BG60 | BG200 |
|---|---|------------------|-------------------|
| Maximum Continuous Load Current (Shutdown Current) | 40 A (45 A) | 60 A (65 A) | 200 A (210 A) |
| Peak Current | 120A | 120A | 480A |
| Operating Voltage | Autodetect 12 or 24VDC 8-19 VDC (12VDC) 20-35 VDC (24VDC) 10 programmable voltage thresholds | | |
| Current Consumption | ~ 4mA | ~ 4mA | ~ 4mA |
| Current Consumption in OFF Position or under- or over- voltage position | ~ 2mA | ~ 2mA | ~ 2mA |
| Overvoltage Shutdown 12V Mode | >16 V | >16 V | >16 V |
| 24V Mode | >32 V | >32 V | >32 V |
| Shutdown at Overload | After 5 sec (after 1 minute start up) | | |
| Connections | On/Off switch Alarm buzzer or relay CurrentWatch current sensor | | |
| Voltage Drop | 0.0875@35A | 0.125@50A | 0.1125@180A |
| Current Output Tolerance | +/-20% | +/-20% | +/-20% |
| Voltage Tolerance | ~2% | ~2% | ~2% |
| Casework | Anodized aluminium black | | |
| Enclosure Type | IP 66 (Watertight) | | |
| Safety & EMC | Emission Immunity Automotive | | |
| | EN50081-1 / EN61000-6-3 EN50082-2 / EN61000-6-1 95/95CE | | |
| Dimensions (D x W x H) | 80 x 60 x 40 mm | 80 x 60 x 40 mm | 110 x 120 x 60 mm |
| Weight | 0.23 Kg / 0.5 lb | 0.23 Kg / 0.5 lb | 0.23 Kg / 0.5 lb |

Note: The above specifications are subject to change without notice



samlexpower

110-17 Fawcett Rd
Coquitlam, B.C.
Canada V3K 6V2

T: 604 525 3836
F: 604 525 5221

e-mail: samlex@samlexamerica.com
website: www.samlexamerica.com